

Ram

Ram Table

Table

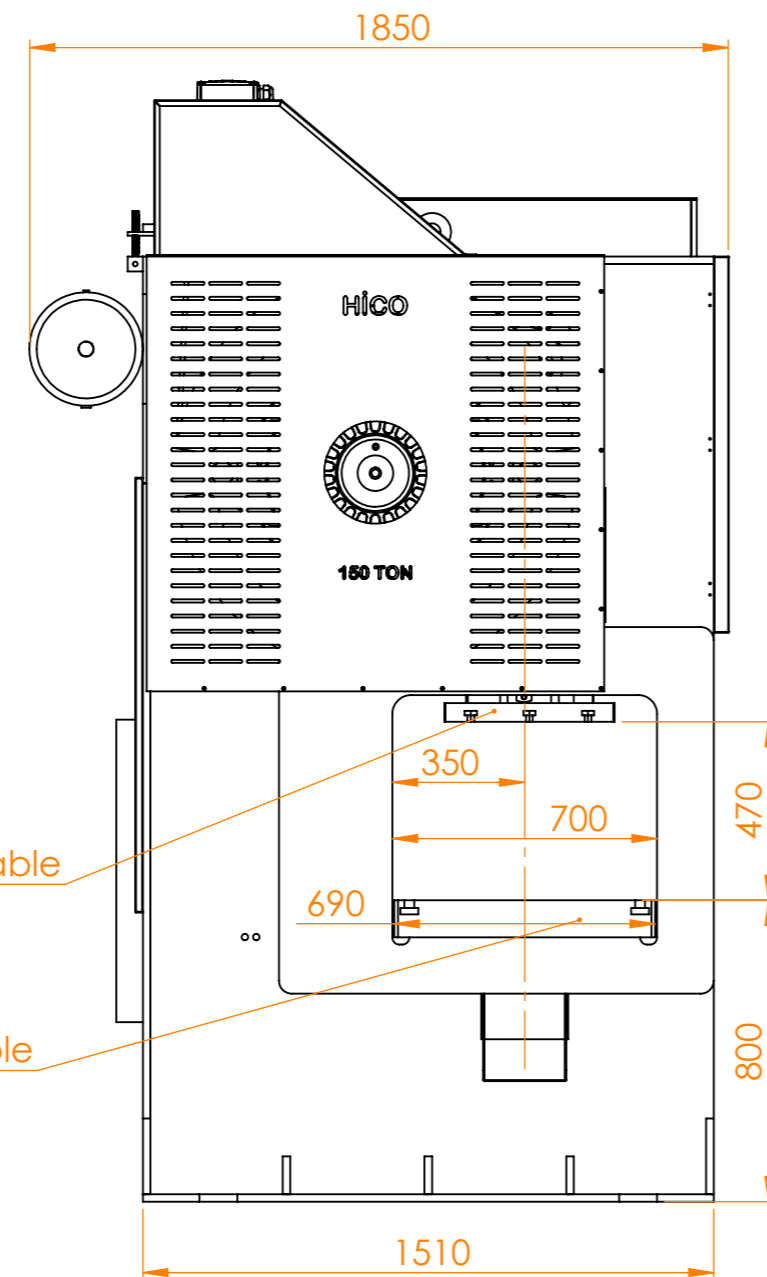

HICO  
150 TON

350  
700

690

470

800

1510

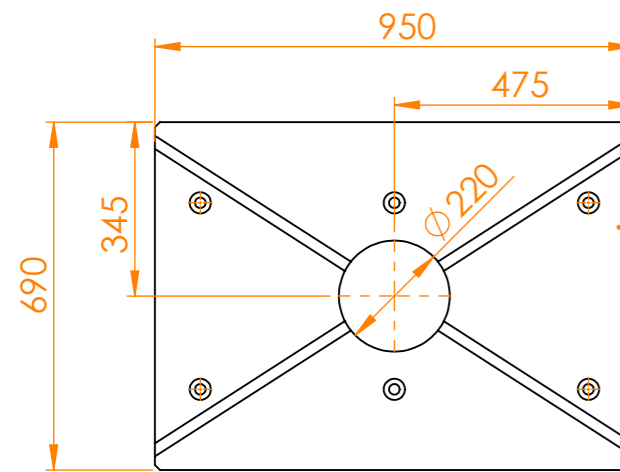

Table

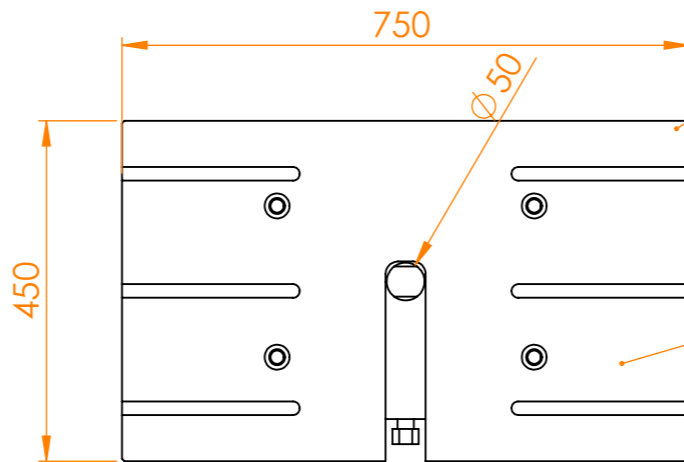

Ram Table

Ram

### Standart Features

- Steel construction body
- Pneumatic clutch and brake combination
- Adjustable stroke
- Eccentric Crankschaft was made filling
- Liner washer system in connecting rod
- Central lubrication system
- Adjustable rear slides
- 6 guide ram
- Ram adjustment with motor
- Hydraulic overload protection system
- Gear box welded to body
- Gears closed system in oil
- Maint table with T slots
- Material and scrap groove
- Automatic Reversible Fluid Lubrication System
- Foot paddle
- Double hand control
- Single-continous-interrupted shot - feeding mode options
- PLC applied
- Crank Angle Indicator with Encoder
- 7" Operator Panel
- 3 Color Warning Light
- Security PLC
- Compliance with CE directives
- Safety light curtains
- Press safety valve
- Pneumatic ram balancing cylinders

### Optional Features

- Speed Control Unit

	Value	Unit
Capacity	150	Ton
Throat Depth	350	mm
Table - Ram Distance	470	mm
Housing Width	650	mm
Ram Adjusment	90	mm
Press Width	1800	mm
Press Height	3000	mm
Press Depth	1850	mm
Table Hole Diameter	Ø220	mm
Table Depth	690	mm
Table Width	950	mm
Die Tie Hole Diameter	Ø50	mm
Ram Face Size	450 x 610	mm
Table Height From Floor	800	mm
Stroke	10-110	mm
Stroke Per Minute	53	spm
Motor Power	15	kW
Motor Speed	1500	rpm
Weight	8000	kg

A3	ISO 128	HP_150_PK_AEP_DT	Technical Specifications			Syf No
TASARIM / DESIGNED	Taha Canat	18.09.2021	RESİM NO / DWG NO	ADET / PIECE		1/2
ÇİZEN / DRAWN	Taha Canat	02.11.2022	PARÇA NO / PART NO	ÖLÇEK / SCALE		
KONTROL / CHECKED			MALZEME / MATERIAL	AĞIRLIK / WEIGHT		
HICO MACHINERY AND ENGINEERING LTD. CO. reserves the right to make changes in dimensions without prior notice.						